

PGEN-10 (10E)

ECS Pre-Engineered Nitrogen Generator



For use under U.S. Patents
8,720,591, 9,144,700 and 9,186,533

Specifications

Cabinet Dimensions:	28.5" (W) x 36.5" (H) x 11.5" (D) 724mm (W) x 927mm (H) x 292mm (D)
Weight:	175 Lbs (79 Kg)
Temperature Range:	40°F - 105°F (5°C - 40°C)
Power Supply:	120VAC/1 phase/60Hz (dedicated circuit) 220-240VAC/1 phase/50Hz (dedicated circuit)
Power Consumption:	14.5 Amps
Nitrogen/Air Connection:	½" NPT Female
Drain Connection:	¼" NPT Female
Approvals:	FM Approved CE Certification UL508A Listed Industrial Control Panel
Optional Configuration:	Cold Environment Installation

Ordering Information

Stock Number:	PGEN-10/(10E)
Replacement Filters:	PGEN-FKW-F (annual maintenance)
Replacement Membrane:	PGEN-MW (20 year expected service life)

General Description

The ECS Pre-Engineered Wall Mount Nitrogen Generator is designed to facilitate the **Dry Pipe Nitrogen Inerting (DPNI)** process for controlling oxygen corrosion in dry pipe and preaction fire sprinkler systems with supervisory nitrogen maintenance gas. The nitrogen generator can be used in **cold storage/freezer applications** due to added benefit of ice plug mitigation. With plug and play performance in a typical dry pipe or preaction fire sprinkler system, the nitrogen generator utilizes membrane separation technology that produces 98%+ nitrogen gas on demand.

The ECS Nitrogen Generator supplies single or multiple sprinkler systems depending on the number of systems, the volume of the largest system, and the cumulative volume of all systems being supplied. The integral air compressor and bypass valve allows for maintenance or "fast fill" needs to meet the NFPA 13 30-minute fill requirement for dry pipe and preaction fire protection systems. Cold storage application requirements vary based on the temperature of refrigerated space - contact ECS for design assistance.

The ECS Nitrogen Generator is designed to inert the supervised sprinkler systems within 14 days and then automatically provide nitrogen gas for pressure maintenance. When paired with either the Protector Dry Manual Vent (PAV-D) or the Protector Dry SMART Vent (PSV-D/DE) **installed on the sprinkler riser**, the nitrogen generator facilitates the patented "fill and purge" breathing process to **remove all the corrosive oxygen gas** in the sprinkler systems **without the need for nitrogen storage**.

The ECS Pre-Engineered Nitrogen Generator is a self-contained wall mounted unit that includes the following components:

- Steel enclosure cabinet with membrane type nitrogen generator (no nitrogen gas storage) and manual bypass
- Power supply - 120VAC/1 phase/60Hz (220-240VAC/1 phase/50Hz)
- Single point nitrogen/air discharge – ½” NPT Female
- Oil less air compressor
- Hour run meter and cycle counter

The ECS Nitrogen Generator includes the following function Indications:

- Bypass Alarm - Nitrogen generator is in the “By-Pass” mode (Flashing Indicator)
- Leak Monitoring - Nitrogen generator running excessively (Audible Signal)

The ECS Nitrogen Generator includes the following monitoring outputs:

- System Power (Digital Output)
- Bypass Mode Alarm (Digital Output)
- Nitrogen Generator Running (Digital Output)
- Leak Monitoring (Digital Output)
- Nitrogen Supply Line Pressure (Analog Output)

The ECS Nitrogen Generator is designed to be used in conjunction with the following components as part of the complete ECS Dry Pipe Nitrogen Inerting (DPNI) system:

- Air maintenance device with on board adjustable regulator (recommend Victaulic Series 757; Tyco AMD-1 or; Reliable Model A)
- Riser-mounted ECS Protector Manual Vent (PAV-D) or ECS Protector Dry SMART Vent (PSV-D/DE)

The ECS Nitrogen Generator can be used with the following optional equipment:

- ECS AdvancedIQ Vent Controller (AVC-1) - serves up to six (6) sprinkler systems
- ECS Protector SMART Gas Analyzer (SGA-1) - one per nitrogen generator is recommended
- ECS In-Line Corrosion Detector (ILD-X) - monitoring at least one per sprinkler system is recommended

Operating Performance

Model Number	Total System Capacity Gallons (Liters)	Single System Capacity † @ 40 psig (2.8 bar) Gallons (Liters)	Single System Capacity † @ 20 psig (1.4 bar) Gallons (Liters)	Sound Level dBA @ 10'
PGEN-10/(10E) ^{††}	2,000 (7,571)	560 (2,120)	1,120 (4,240)	73

† Capacity based on NFPA 13 30-minute fill requirement of largest single system

†† Nitrogen production is less than 5.5 ft³/min (160 L/min) at 10 psi (0.7 bar) as defined in NFPA 13

Nitrogen Quality

N ₂ Purity at Discharge:	98% or greater (maximum of 2.0% oxygen)
N ₂ Pressure at Discharge:	Min of 15 psig (1 bar); Max of feed air pressure minus 15 psig (1 bar)
N ₂ Water Dew Point:	Typically less than -70°F (-57°C)

NOTE:

When connecting an ECS Protector Nitrogen Generator to an existing dry pipe/preaction fire sprinkler system, the existing fire sprinkler system(s) must be limited to a maximum leak rate of less than 6 psig (.4 bar) within a 24 hour period, per system.

Installation Instructions

Installation of the ECS Nitrogen Generator requires five (5) steps:

1. Mount the nitrogen generator cabinet on the wall in the appropriate location within the riser room
2. Connect the dedicated power supply circuit in the cabinet
3. Plumb the nitrogen/air supply line to the water based fire sprinkler risers being served
4. Plumb the drain line to floor drain or building exterior
5. Connect nitrogen generator output signals to BMS or fire alarm system, where applicable

Step 1: Mounting the Wall Mounted Nitrogen Generator

The ECS Nitrogen Generator is designed to be mounted directly to the wall at the installation location. Several factors should be considered in choosing the proper mounting location for the nitrogen generator:

- Access to the power supply (dedicated circuit)
- Access to the sprinkler riser being supplied from the nitrogen generator
- Access to the condensate drain discharge line
- Clearance at the front of the unit to open the cabinet door
- Clearance around ventilation vents on side and bottom for proper cabinet ventilation
- Ability to support cabinet weight at mounting location

The nitrogen generator cabinet assembly includes a mounting rail for wall mounting using standard anchors.

Step 2: Power Supply

The Nitrogen Generator requires a dedicated power supply that connects to the terminal blocks in the nitrogen generator cabinet.

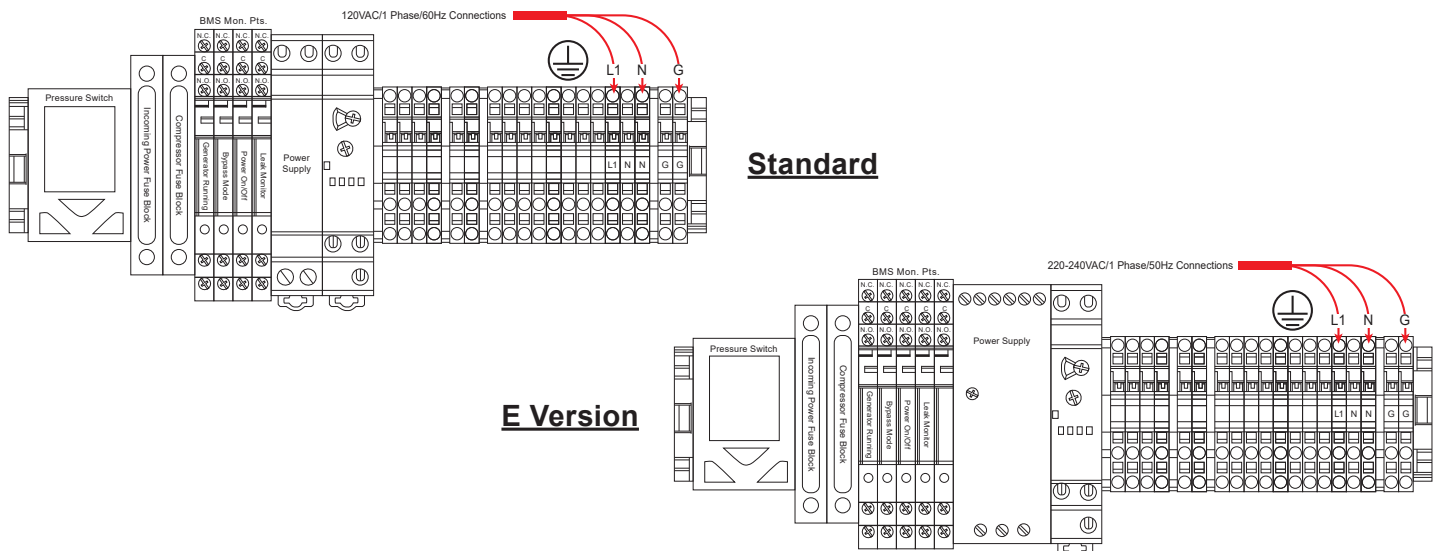

Step 3: Plumb the Nitrogen/Air Supply Line

The nitrogen/air discharge plumbing from the nitrogen generator is to be connected directly to the sprinkler system valve trim using a minimum of 1/2" black steel, galvanized steel or copper piping. The size of the nitrogen/air supply line is to be based on the length of pipe between the nitrogen generator and the fire sprinkler systems along with the total volume of the fire sprinkler systems being supplied. The nitrogen generator requires an in-line Air Maintenance Device (AMD) that is equipped with an on board field adjustable pressure regulator for each zone being served. The preferred AMD is the Victaulic Series 757.

NOTE: When both dry pipe and preaction fire sprinkler systems are connected to one nitrogen generator, additional equipment may be required if the fire sprinkler systems operate at different supervisory gas pressures.

Step 4: Plumb the Condensate Drain Line

The ECS Protector Nitrogen Generator will occasionally discharge a small amount of condensate water from the coalescing filters inside the cabinet. It is recommended that the ¼” drain connection be plumbed to a floor drain or building exterior. When plumbing to a drain is not feasible an evaporative collection chamber can be used.

Step 5: System Signals and Monitoring, where used

The nitrogen generator cabinet has two (2) system signals and five (5) outputs that can be monitored by the facility’s BMS or fire alarm system.

- Bypass Alarm - The nitrogen generator is operating in the bypass mode which is activated when the bypass valve is in the “fast fill” position to fast fill the fire sprinkler system and the air supplied directly from the air compressor has reached a pressure of 20 psig (1.4 bar). (Flashing amber light)
- Leak Monitor - The nitrogen generator is equipped with a leak monitor audible signal which is activated when the nitrogen generator runs excessively. (Audible signal)

The nitrogen generator cabinet includes system monitoring signals which can be monitored through a building monitoring system, if desired:

- Nitrogen Generator Running - Form C contacts
- Bypass Mode Alarm - Form C contacts
- Nitrogen Generator Power Monitoring - Form C contacts
- Leak Monitoring - Form C contacts
- Nitrogen System Supply Line Pressure - Analog Signal

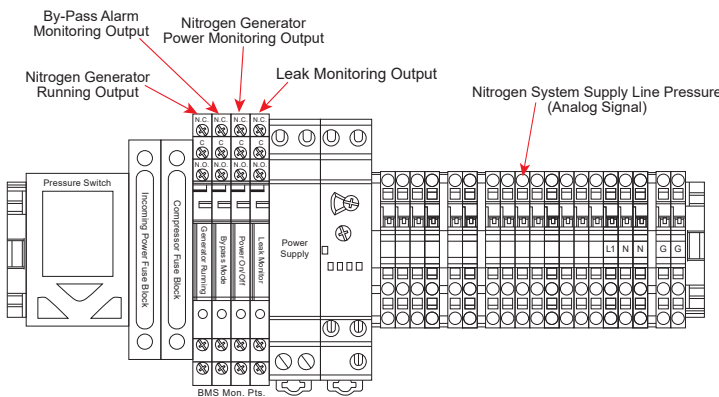

Standard

E Version

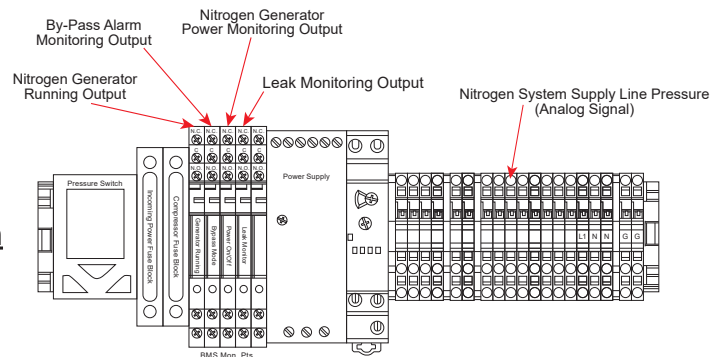

ECS Pre-Engineered Nitrogen Generation System

(typical installation schematic)

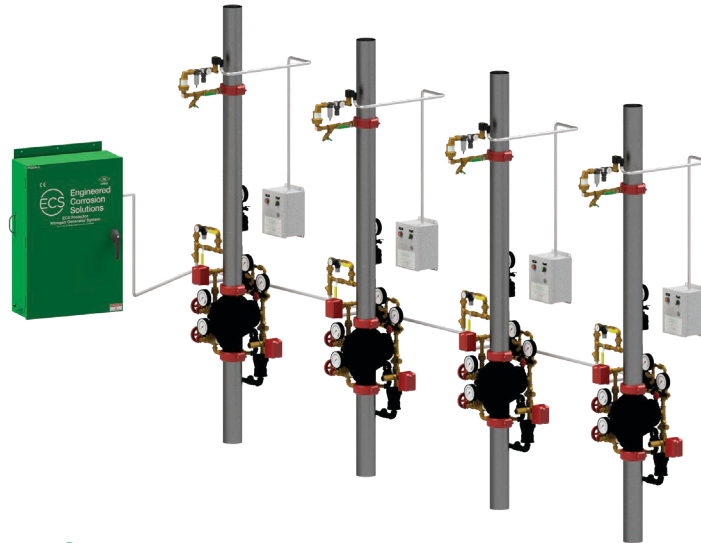

Maintenance of the Nitrogen Generator:

The nitrogen generator cabinet contains three (3) separate cartridge filters and water separator. **It is recommended that each of the filter cartridges be replaced as part of an annual preventative maintenance program.** In some environments it may be necessary to replace filters more frequently. The filter replacement kit for the nitrogen generator is part number PGEN-FKW-F. When maintained properly the nitrogen separation membrane will provide up to 20 years of service life.

Filter Replacement Procedure

Preliminary Steps (taking the nitrogen generator out of service)

1. Turn the power supply to the unit off
2. Close the regulated and fast fill valves on fire sprinkler system's air maintenance device(s)
3. Turn the bypass valve in the nitrogen generator to the "fast fill" position
4. The Nitrogen Generator is designed to depressurize the inlet piping through the permeate of the nitrogen separation membrane when the nitrogen generator automatically shuts off

To replace the filter cartridges follow Step 1 through Step 6.

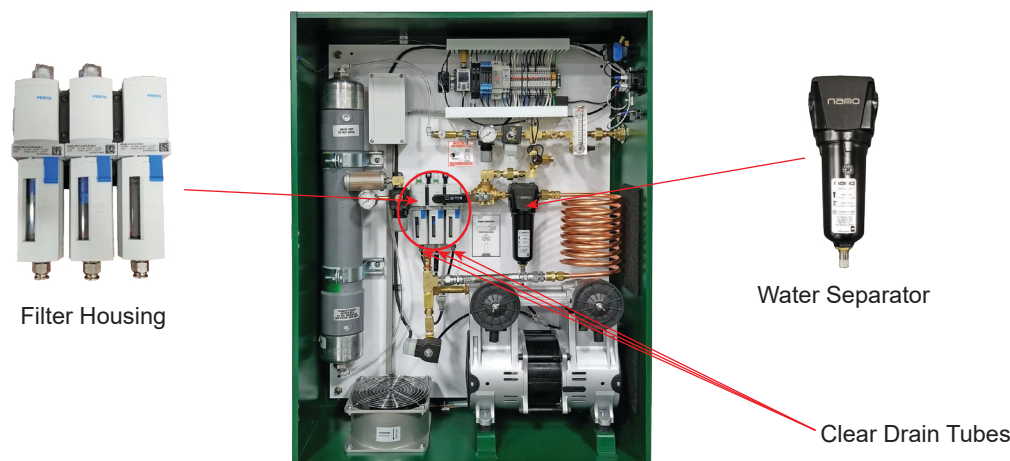

Step 1: Remove the filter housing by pulling down on the blue housing lock and turning the filter housing counter-clock wise.

Step 2: Once the filter housing has been removed, the filter cartridge inside is removed by first unscrewing the black retaining disc at the base of the cartridge and then pulling down on the cartridge. Discard the old filter cartridge and replace it with the appropriately marked filter cartridge from the filter replacement kit by pushing up so that it fits snugly onto the receiving cylinder in the upper part of the filter housing. Screw the black retaining disc back onto the threaded rod.

Important: HAND TIGHTEN ONLY!

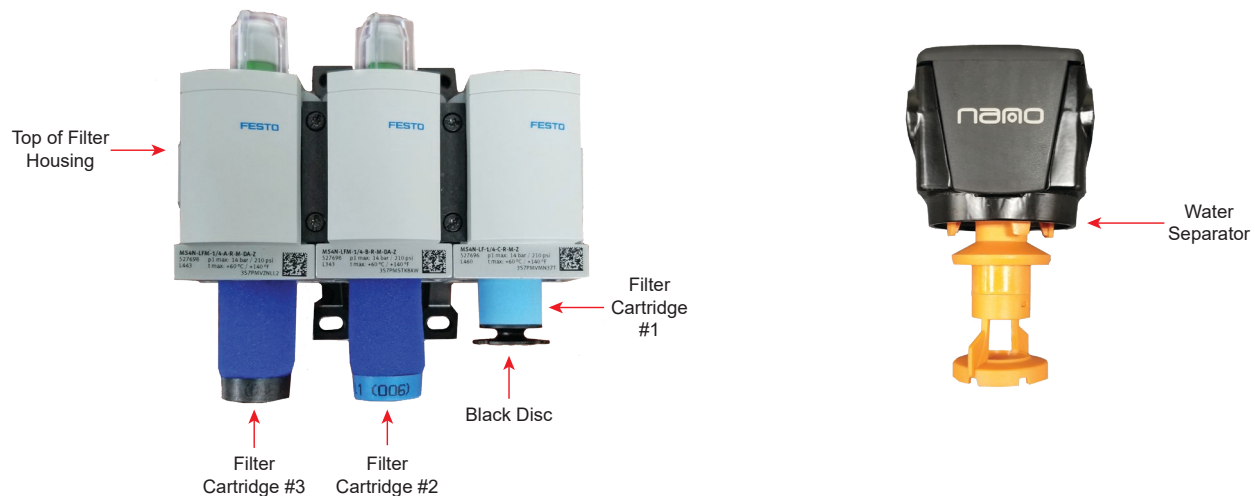

Step 3: Replace the filter housing by pushing up into position and turning housing clockwise until blue housing lock latches into place.

Step 4: Repeat Step 1 through Step 3 for each additional filter. (**NOTE:** Filters 2 & 3 do not have a black retaining disc, filters screw directly into housing)

Step 5: Remove water separator housing and inspect water separator. Clean as necessary.

Step 6: The ECS Protector Nitrogen Generator can now be placed back into service.

Return the Nitrogen Generator to Service

1. Turn the power supply to the unit on
2. Open the regulated valve on fire sprinkler system's air maintenance device(s)
3. Turn the bypass valve in the nitrogen generator to the "nitrogen generation" position

ECS Protector Nitrogen Generator Optional Monitoring Equipment

- **ECS AdvancedIQ Vent Controller (AVC-1):** monitors system pressure, monitors nitrogen purity, and controls DPNI process in up to six (6) sprinkler systems. Information is digitally and graphically displayed as well as saved for future use.
- **ECS Protector Handheld Gas Analyzer (PHGA-1):** portable analyzer to measure nitrogen concentration at nitrogen generator cabinet or gas sampling ports on ECS oxygen removal vents.
- **ECS Protector SMART Gas Analyzer (SGA-1):** installed in the riser room to continuously monitor nitrogen gas concentration (digitally displayed) and transmit to a building alarm or management system.
- **ECS In-Line Corrosion Detector (ILD-X):** installed in-line within the fire sprinkler system piping at locations most susceptible to corrosion; provides either a local test indicator or monitoring through building alarm or management system.