

PAV-W/WS

ECS Ejector Automatic Air Vent

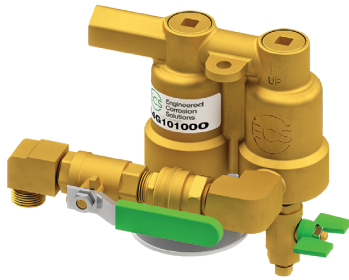

Features

ECS Ejector Automatic Air Vent (U.S. Patents No. 8,636,023)

- Patented redundant float design - Eliminates piping to a drain
- Quick Connect - Easy installation and servicing
- Pressure Gauge - Visual monitoring from the floor
- Isolation Ball Valve Included
- Available in Supervised (PAV-WS)
- Entire Assembly is FM 1344 Approved - Air Vents for Automatic Sprinkler Systems
- Entire Assembly is UL VPMG Listed - Valves, Automatic Air Release

General Description

The ECS Ejector Automatic Air Vent (PAV-W/WS) is a device that provides automatic venting of trapped air in wet pipe fire sprinkler systems. As a fire sprinkler system is filled with water, trapped air migrates to the high point of the system near the vent installation location which allows for trapped air to be vented. Trapped air contains oxygen which is the primary cause of corrosion in fire sprinkler systems. Corrosion in wet pipe fire sprinkler systems is directly proportional to the amount of oxygen trapped within the system piping, so a reduction in trapped air will in turn reduce the internal corrosion activity of the fire sprinkler system. Venting the trapped air in a wet pipe sprinkler system can improve water delivery time and reduce false water flow alarms.

The float mechanism on the ECS Ejector Automatic Air Vent will automatically close when water reaches the vent and the redundant design eliminates the need to plumb the PAV-W/WS to drain. If the primary float valve allows any significant amount of water to leak past it, the second float valve will close preventing water from discharging and provide a system pressure reading on the pressure gauge. This condition will be an indication that the primary automatic gas vent valve has failed and requires service or replacement. The pressure gauge is designed to be visible from the floor below the ECS Ejector Automatic Air Vent from a distance of approximately 30 feet.

There are two available models of the ECS Ejector Automatic Air Vent: PAV-W and PAV-WS. The units both operate as described previously; however, the PAV-WS includes a single contact rated 24VAC/DC @ 2A for electronic monitoring. When connected to a building alarm system, connect the contact of the PAV-WS using the appropriate end-of-line supervision device, as required by the building alarm manufacture.

Specifications

Dimensions	8" (W) x 7" (H) x 6" (D) 203.2mm (W) x 177.8mm (H) x 152.4mm (D)
Weight	7 Lbs (3kg)*
Service Pressure	Up to 175 PSIG (12 Bar)
System Connection	½" NPT Male (12.7mm)
Temperature Range	40°F - 175°F (5°C - 79°C)
Clear Height	5" (127mm)

*Support Hanger Not Required

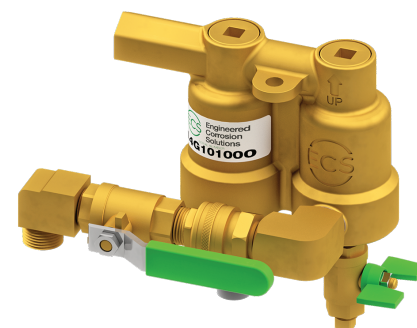

PAV-WS

PAV-W/WS

ECS Ejector Automatic Air Vent

PAV-W

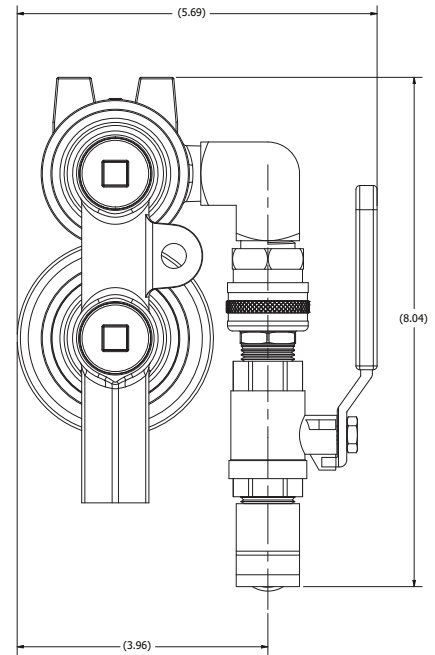
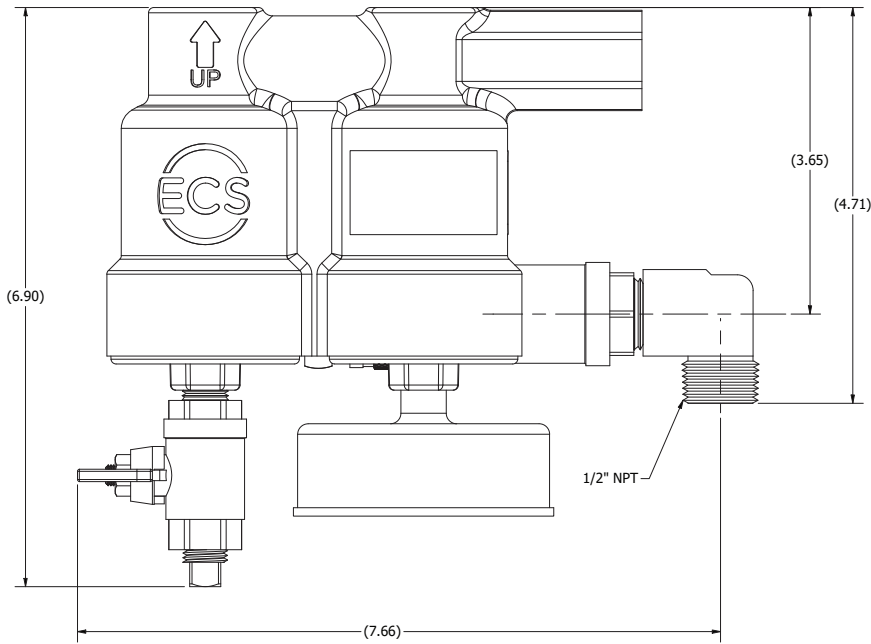

PAV-WS

